



Exhaust centrifugal fan

Extero

Air capacity — up to 710 m³/h

■ Use

- Exhaust ventilation systems installed in various premises.
- External wall mounting from outside.
- Compatible with Ø100 up to 200 mm round air ducts.

■ Design

- Steel casing with a special polymer atmospheric resistant coating.
- Specially designed casing protects motor against direct sprays of water.
- Vertical air exhaust downwards through a protecting screen against birds and rodents.
- Back side has a special sealant for tight contact and adaption to the wall.
- Connecting branch pipe is equipped with rubber seal.

■ Motor

- Single-phase external rotor motor with a centrifugal impeller with backward curved blades.
- Equipped with ball bearings for longer service life.
- Integrated thermal protection with automatic restart.
- Dynamically balanced turbine.

■ Speed control

- Smooth or step speed control with a thyristor or autotransformer speed controller (available upon order) connected to the maximum speed terminal of the motor.

■ Mounting

- Vertical mounting on external walls of buildings and premises.
- Flexible air duct is fixed on fan branch pipe with a clamp.
- The fan with connected air duct is fixed at the wall on a mounting plate. Power supply through the external terminals. After mounting of the ventilator a protection cover is mounted over the mounting plate.

■ Specifications

Parameters	Extero 100	Extero 125	Extero 150	Extero 160	Extero 200
Voltage [V / 50 Hz]	230	230	230	230	230
Power [W]	58	60	100	102	104
Current [A]	0,26	0,27	0,43	0,44	0,45
Maximum air capacity [m ³ /h]	280	390	600	650	710
RPM [min ⁻¹]	2500	2500	2600	2600	2600
Sound pressure level at 3 m distance [dBA]	54	54	58	60	62
Max. operating temperature [°C]	55	55	55	55	55
Ingress protection rating	IP X4	IP X4	IP X4	IP X4	IP X4

Specifications

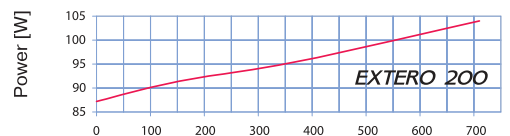
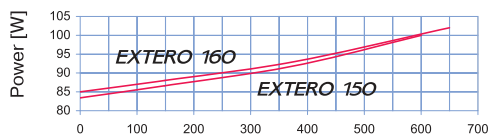
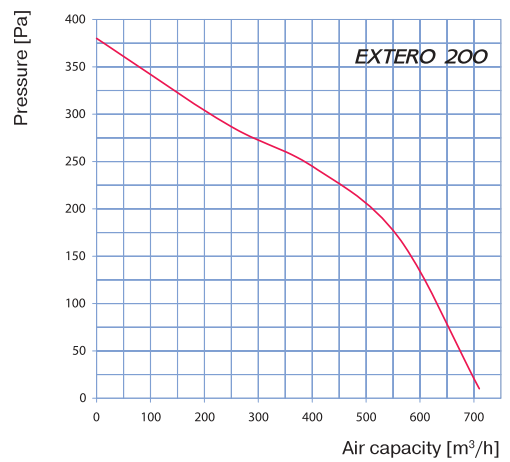
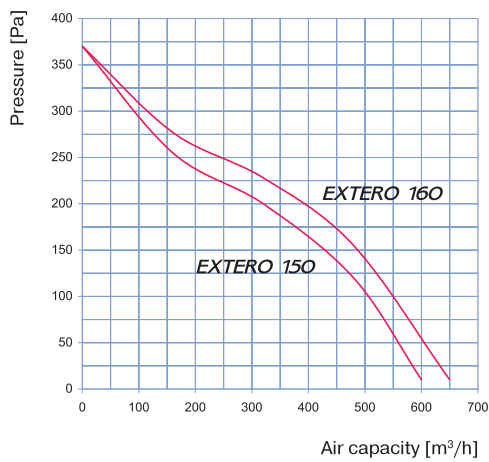
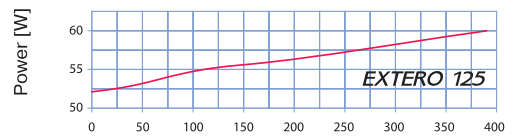
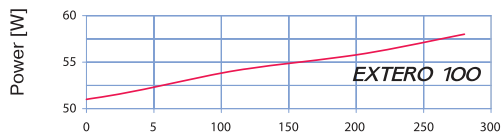
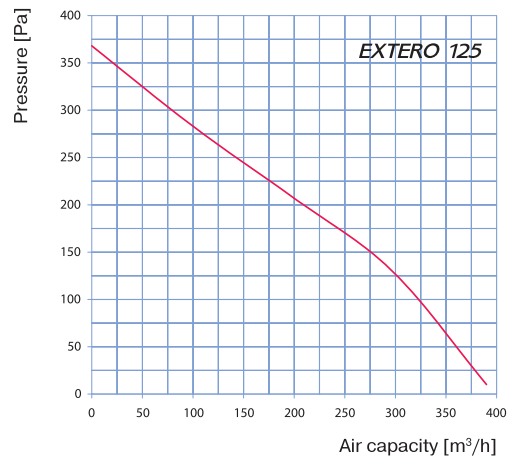
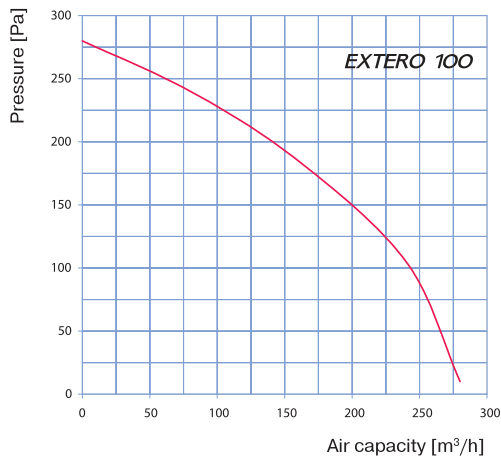

Overall dimensions

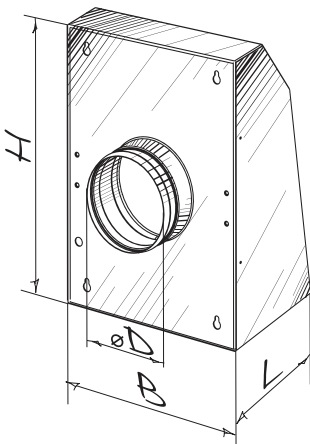

Type	Dimensions [mm]				Weight [kg]
	ØD	B	H	L	
Extero 100	99	260	355	138	4,1
Extero 125	124	260	355	138	4,1
Extero 150	149	300	400	138,2	4,5
Extero 160	159	300	400	138,2	4,5
Extero 200	199	300	400	138,2	4,5