



BS 5750 Pt 1
EN 29001
ISO 9001

Fan Code: 140JM/40/8/6/...

1400 mm 720 rev/min 6 Blades 50 Hz

Performance Data ISO 5801: The AMCA Certified Ratings Seal applies to air performance only

Performance shown is for installations type C – Ducted inlet, Ducted outlet. Performance ratings do not include the effects of appurtenances.

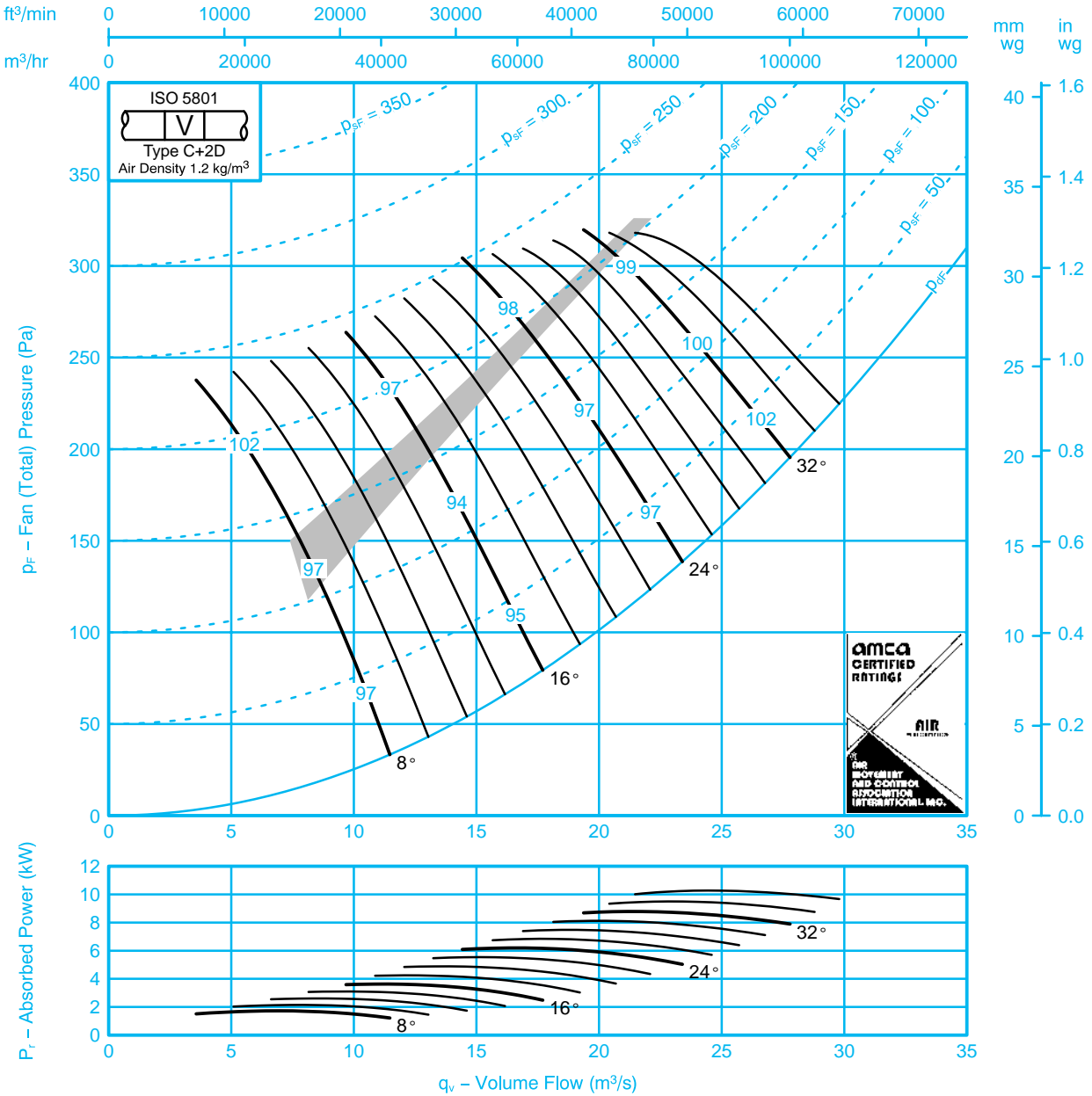

Sound Data BS848 Part 2 1985:

Single figures on performance curves are overall inlet sound power levels, derived from measurements taken in Woods laboratory specifically under ducted conditions. For sound power levels in eight octave bands, apply the following corrections to the overall level. Use upper corrections when operating point is above shaded area, or lower corrections when operating point is below shaded area.

Inlet Levels									Outlet Levels								
Pitch Angle	Octave Band Centre Frequency (Hz)								Pitch Angle	Octave Band Centre Frequency (Hz)							
	63	125	250	500	1k	2k	4k	8k		63	125	250	500	1k	2k	4k	8k
8	-19	-13	-8	-3	-8	-11	-17	-27	8	-15	-11	-7	-3	-7	-9	-16	-26
	-17	-11	-11	-6	-6	-6	-13	-25		-13	-9	-10	-5	-6	-5	-11	-24
16	-15	-10	-7	-3	-9	-14	-20	-23	16	-12	-8	-7	-3	-9	-14	-18	-22
	-9	-6	-8	-9	-10	-8	-13	-21		-6	-4	-8	-9	-10	-7	-12	-21
24-36	-9	-5	-7	-7	-11	-14	-16	-17	24-36	-6	-4	-7	-6	-10	-13	-14	-16
	-7	-5	-7	-8	-12	-14	-15	-17		-4	-4	-6	-6	-12	-13	-13	-16

Performance Data ISO 5801: The AMCA Certified Ratings Seal applies to air performance only

Performance shown is for installations type C – Ducted inlet, Ducted outlet. Performance ratings do not include the effects of appurtenances.

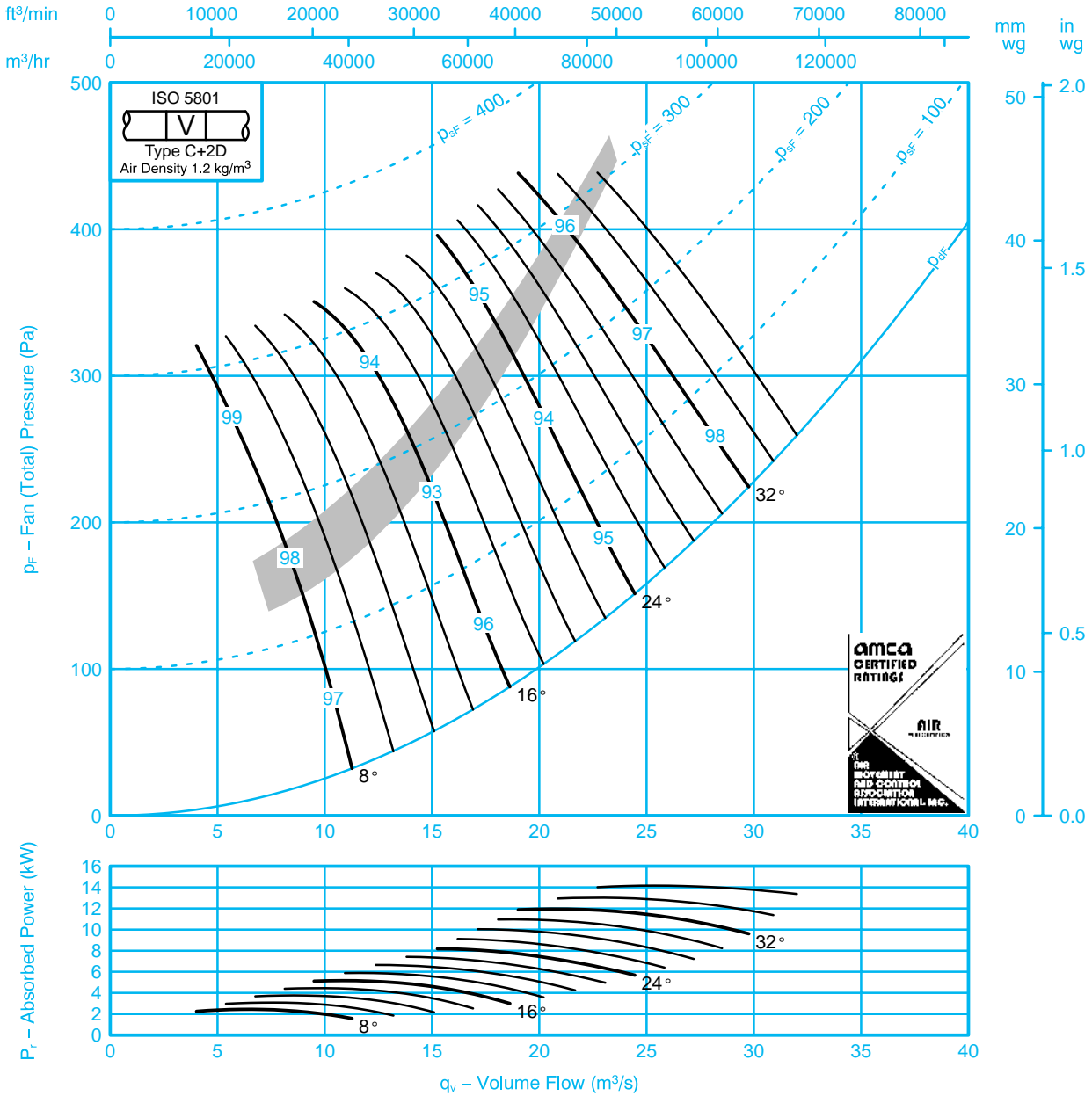

Sound Data BS848 Part 2 1985:

Single figures on performance curves are overall inlet sound power levels, derived from measurements taken in Woods laboratory specifically under ducted conditions. For sound power levels in eight octave bands, apply the following corrections to the overall level. Use upper corrections when operating point is above shaded area, or lower corrections when operating point is below shaded area.

Inlet Levels									Outlet Levels								
Pitch Angle	Octave Band Centre Frequency (Hz)								Pitch Angle	Octave Band Centre Frequency (Hz)							
	63	125	250	500	1k	2k	4k	8k		63	125	250	500	1k	2k	4k	8k
8	-17	-13	-8	-3	-7	-11	-19	-27	8	-14	-11	-8	-2	-6	-10	-19	-26
	-18	-13	-11	-7	-7	-4	-12	-24		-15	-10	-11	-5	-5	-3	-12	-23
16	-8	-10	-9	-6	-8	-9	-14	-18	16	-4	-8	-8	-6	-7	-8	-12	-17
	-12	-10	-10	-8	-8	-5	-12	-20		-8	-7	-8	-8	-7	-4	-12	-18
24 - 36	-7	-7	-8	-7	-9	-13	-15	-14	24 - 36	-3	-3	-6	-7	-9	-12	-13	-13
	-7	-7	-7	-7	-9	-12	-15	-17		-3	-3	-5	-6	-8	-11	-13	-16

Performance Data ISO 5801: The AMCA Certified Ratings Seal applies to air performance only

Performance shown is for installations type C – Ducted inlet, Ducted outlet. Performance ratings do not include the effects of appurtenances.

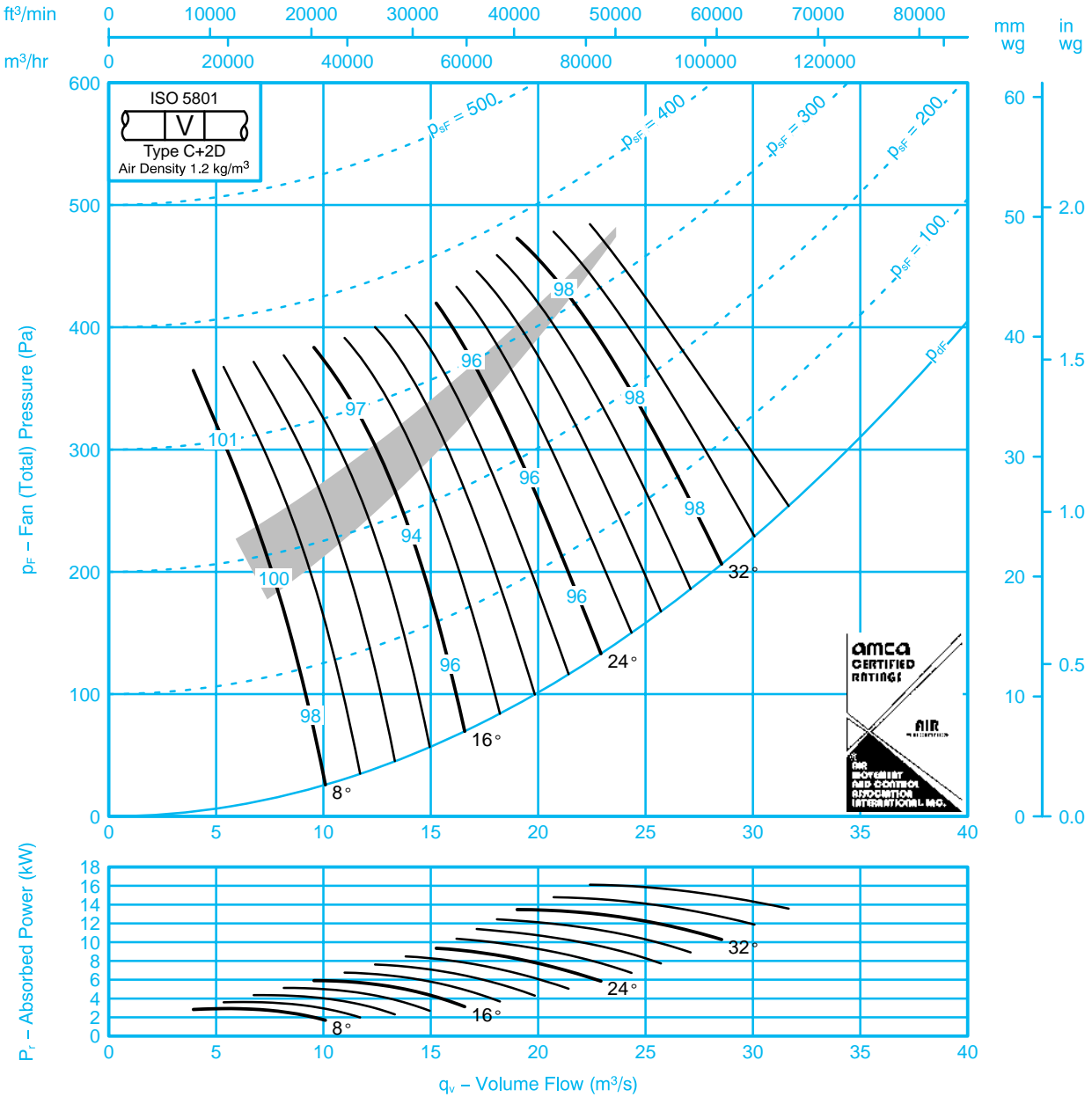

Sound Data BS848 Part 2 1985:

Single figures on performance curves are overall inlet sound power levels, derived from measurements taken in Woods laboratory specifically under ducted conditions. For sound power levels in eight octave bands, apply the following corrections to the overall level. Use upper corrections when operating point is above shaded area, or lower corrections when operating point is below shaded area.

Inlet Levels									Outlet Levels								
Pitch Angle	Octave Band Centre Frequency (Hz)								Pitch Angle	Octave Band Centre Frequency (Hz)							
	63	125	250	500	1k	2k	4k	8k		63	125	250	500	1k	2k	4k	8k
8	-16	-8	-8	-4	-8	-14	-23	-30	8	-14	-5	-8	-3	-7	-12	-21	-28
	-18	-12	-10	-5	-6	-7	-14	-24		-15	-9	-10	-4	-5	-5	-12	-22
16	-16	-12	-5	-4	-9	-17	-25	-28	16	-13	-9	-4	-4	-9	-16	-22	-26
	-11	-5	-11	-8	-8	-7	-14	-21		-8	-2	-10	-8	-8	-6	-11	-18
24-36	-6	-6	-10	-8	-10	-14	-17	-16	24-36	-3	-2	-8	-7	-9	-14	-15	-15
	-7	-5	-9	-8	-10	-12	-17	-20		-3	-1	-7	-7	-9	-11	-16	-19



Fan Code: 140JM/40/6/6/...

1400 mm 960 rev/min 6 Blades 50 Hz

Performance Data ISO 5801: The AMCA Certified Ratings Seal applies to air performance only

Performance shown is for installations type C – Ducted inlet, Ducted outlet. Performance ratings do not include the effects of appurtenances.

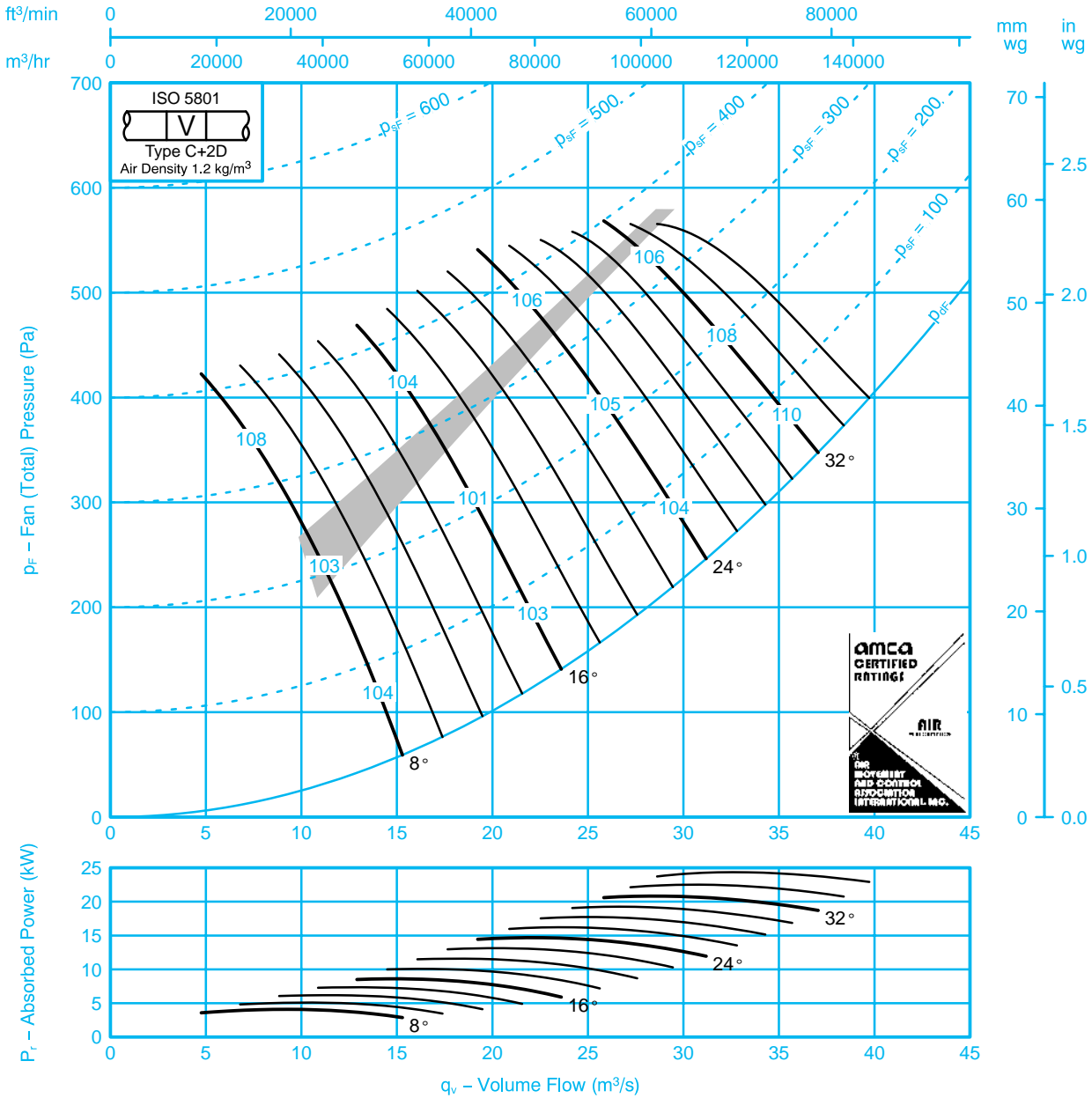

If it is intended to run this fan in reverse for other than emergency operation, please refer to Woods Air Movement.

Sound Data BS848 Part 2 1985:

Single figures on performance curves are overall inlet sound power levels, derived from measurements taken in Woods laboratory specifically under ducted conditions. For sound power levels in eight octave bands, apply the following corrections to the overall level. Use upper corrections when operating point is above shaded area, or lower corrections when operating point is below shaded area.

Inlet Levels									Outlet Levels								
Pitch Angle	Octave Band Centre Frequency (Hz)								Pitch Angle	Octave Band Centre Frequency (Hz)							
	63	125	250	500	1k	2k	4k	8k		63	125	250	500	1k	2k	4k	8k
8	-15	-14	-12	-4	-6	-11	-13	-26	8	-12	-11	-11	-3	-5	-9	-12	-24
	-12	-11	-12	-8	-6	-7	-8	-23		-9	-9	-11	-7	-5	-6	-7	-22
16	-12	-10	-11	-4	-7	-13	-18	-23	16	-10	-9	-10	-3	-7	-13	-16	-21
	-6	-7	-9	-10	-12	-10	-10	-22		-2	-5	-9	-10	-12	-10	-9	-21
24-36	-7	-5	-9	-8	-10	-14	-16	-18	24-36	-4	-4	-8	-7	-9	-12	-14	-16
	-5	-7	-9	-8	-11	-14	-16	-18		-1	-5	-7	-7	-11	-13	-14	-17



BS 5750 Pt 1
EN 29001
ISO 9001

Fan Code: 140JM/40/6/9/...

1400 mm 960 rev/min 9 Blades 50 Hz

Performance Data ISO 5801: The AMCA Certified Ratings Seal applies to air performance only

Performance shown is for installations type C – Ducted inlet, Ducted outlet. Performance ratings do not include the effects of appurtenances.

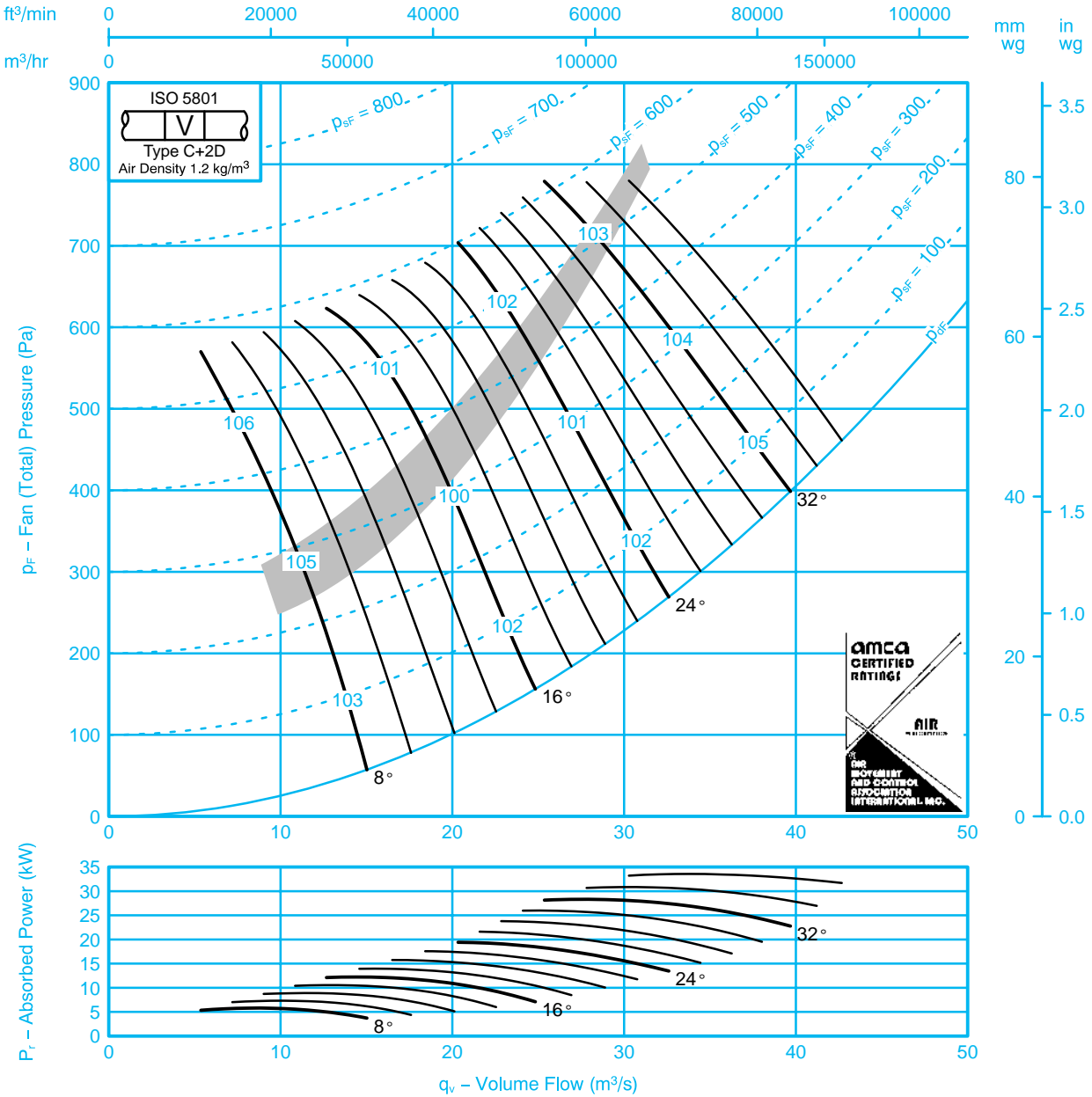

If it is intended to run this fan in reverse for other than emergency operation, please refer to Woods Air Movement.

Sound Data BS848 Part 2 1985:

Single figures on performance curves are overall inlet sound power levels, derived from measurements taken in Woods laboratory specifically under ducted conditions. For sound power levels in eight octave bands, apply the following corrections to the overall level. Use upper corrections when operating point is above shaded area, or lower corrections when operating point is below shaded area.

Inlet Levels									Outlet Levels								
Pitch Angle	Octave Band Centre Frequency (Hz)								Pitch Angle	Octave Band Centre Frequency (Hz)							
	63	125	250	500	1k	2k	4k	8k		63	125	250	500	1k	2k	4k	8k
8	-19	-15	-12	-4	-5	-11	-14	-26	8	-15	-12	-10	-2	-4	-9	-14	-25
	-18	-13	-14	-9	-7	-6	-7	-22		-15	-10	-13	-7	-5	-4	-6	-20
16	-7	-9	-11	-7	-8	-10	-11	-18	16	-4	-6	-10	-7	-7	-9	-9	-17
	-12	-9	-11	-10	-9	-6	-7	-20		-8	-6	-10	-9	-8	-5	-7	-17
24-36	-6	-6	-10	-8	-9	-12	-15	-15	24-36	-2	-3	-8	-7	-8	-11	-14	-14
	-7	-6	-9	-8	-9	-11	-14	-18		-3	-3	-6	-7	-8	-11	-12	-16

Performance Data ISO 5801: The AMCA Certified Ratings Seal applies to air performance only

Performance shown is for installations type C – Ducted inlet, Ducted outlet. Performance ratings do not include the effects of appurtenances.

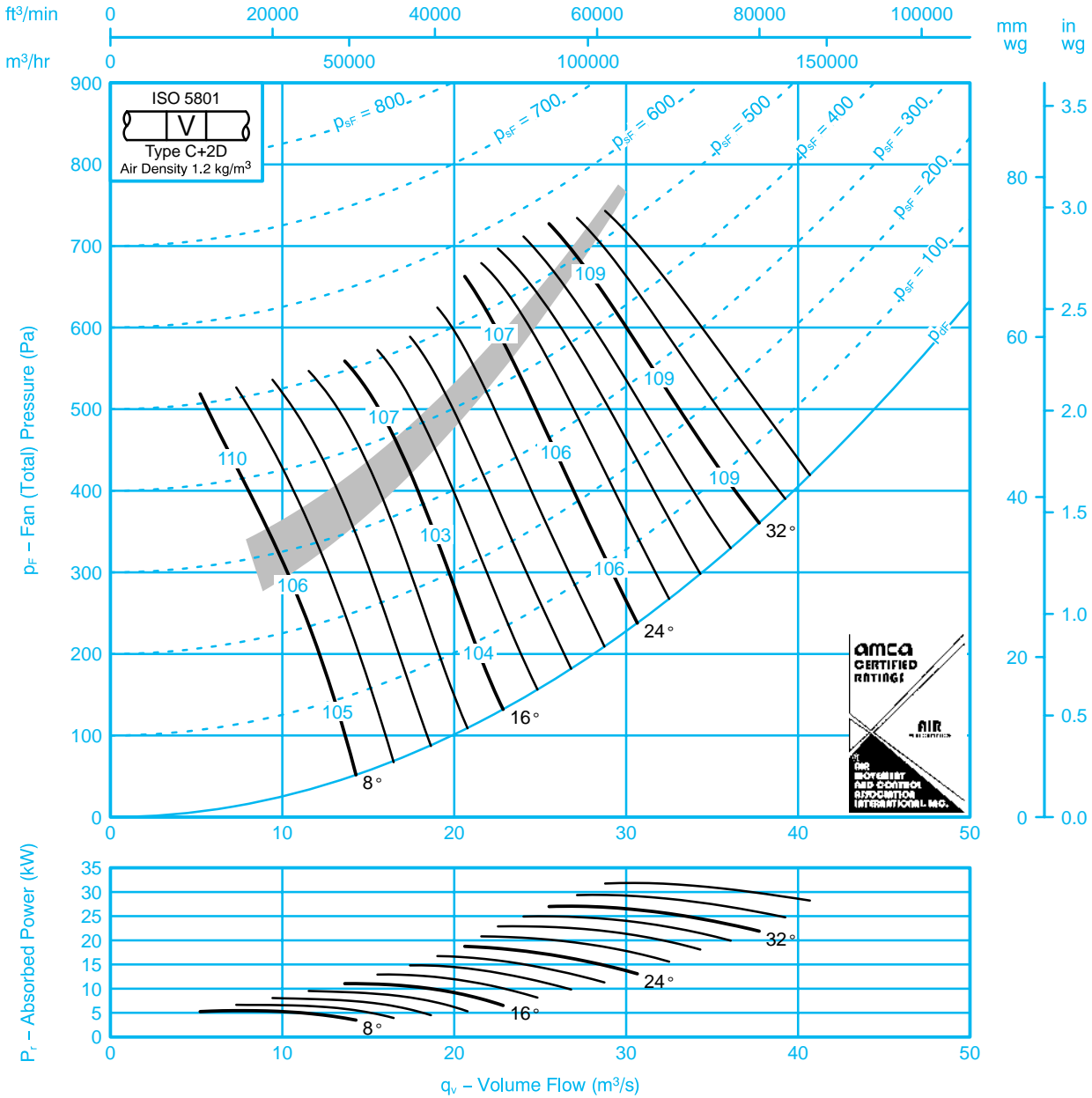

Sound Data BS848 Part 2 1985:

Single figures on performance curves are overall inlet sound power levels, derived from measurements taken in Woods laboratory specifically under ducted conditions. For sound power levels in eight octave bands, apply the following corrections to the overall level. Use upper corrections when operating point is above shaded area, or lower corrections when operating point is below shaded area.

Inlet Levels									Outlet Levels								
Pitch Angle	Octave Band Centre Frequency (Hz)								Pitch Angle	Octave Band Centre Frequency (Hz)							
	63	125	250	500	1k	2k	4k	8k		63	125	250	500	1k	2k	4k	8k
8	-15	-10	-9	-4	-6	-12	-15	-27	8	-12	-8	-8	-3	-5	-11	-15	-25
	-12	-11	-11	-6	-6	-8	-11	-24		-9	-8	-10	-5	-5	-7	-9	-22
16	-12	-12	-9	-3	-8	-13	-18	-24	16	-9	-9	-7	-3	-6	-12	-16	-23
	-7	-8	-8	-9	-9	-9	-11	-20		-5	-5	-6	-7	-8	-7	-10	-19
24 - 36	-6	-5	-9	-9	-11	-14	-16	-18	24 - 36	-4	-2	-8	-7	-10	-13	-15	-17
	-5	-5	-9	-10	-13	-14	-16	-19		-3	-2	-7	-8	-11	-13	-14	-18

Performance Data ISO 5801: The AMCA Certified Ratings Seal applies to air performance only

Performance shown is for installations type C – Ducted inlet, Ducted outlet. Performance ratings do not include the effects of appurtenances.

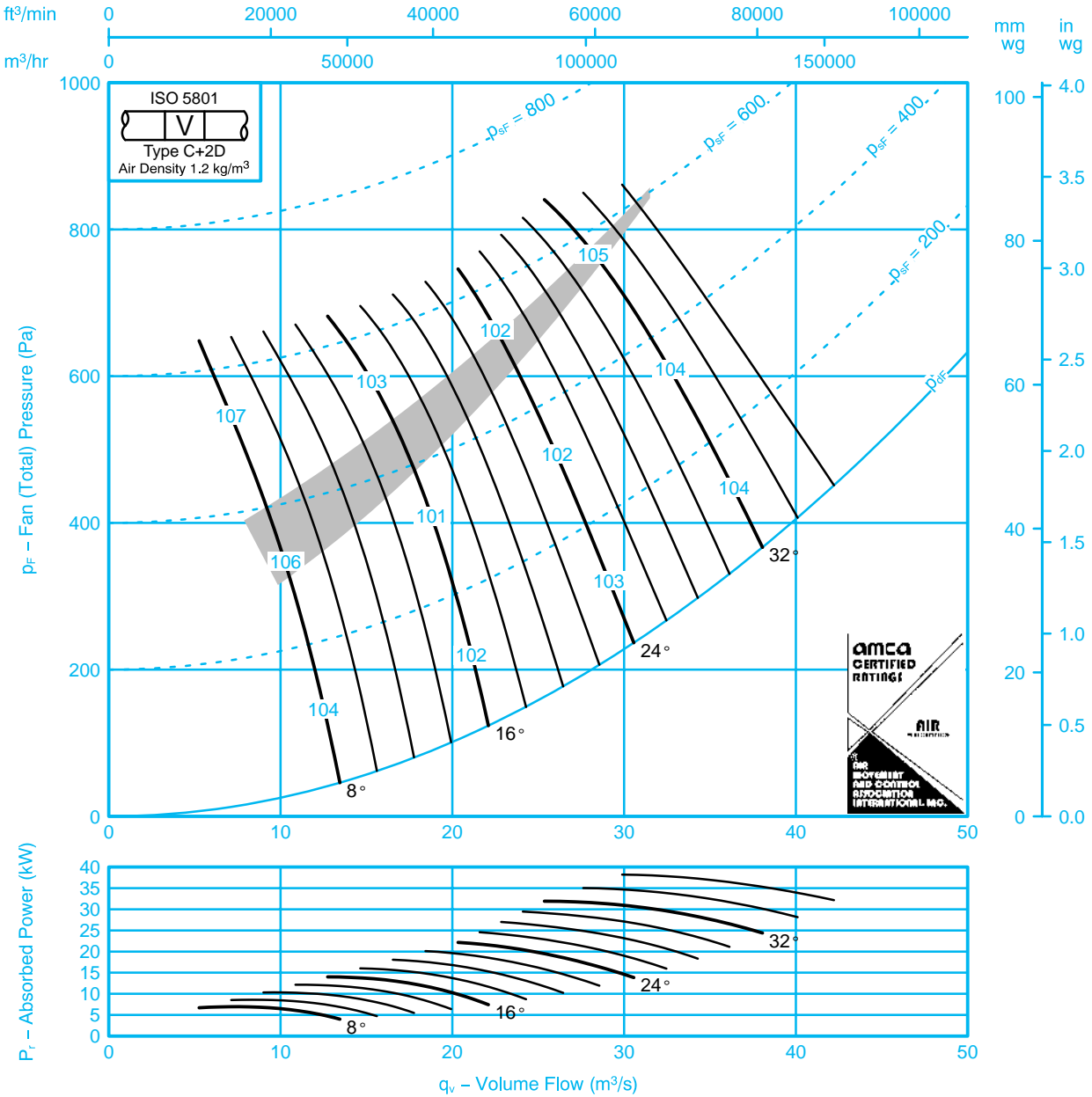

Sound Data BS848 Part 2 1985:

Single figures on performance curves are overall inlet sound power levels, derived from measurements taken in Woods laboratory specifically under ducted conditions. For sound power levels in eight octave bands, apply the following corrections to the overall level. Use upper corrections when operating point is above shaded area, or lower corrections when operating point is below shaded area.

Inlet Levels									Outlet Levels								
Pitch Angle	Octave Band Centre Frequency (Hz)								Pitch Angle	Octave Band Centre Frequency (Hz)							
	63	125	250	500	1k	2k	4k	8k		63	125	250	500	1k	2k	4k	8k
8	-17	-11	-9	-4	-6	-13	-18	-29	8	-15	-9	-7	-3	-5	-10	-16	-27
	-19	-14	-12	-6	-5	-7	-9	-22		-16	-13	-10	-6	-4	-5	-7	-20
16	-16	-15	-9	-3	-7	-14	-21	-27	16	-12	-13	-7	-3	-6	-13	-19	-26
	-10	-11	-7	-9	-8	-8	-9	-20		-7	-9	-4	-9	-8	-6	-6	-17
24-36	-5	-8	-8	-9	-9	-13	-16	-17	24-36	-2	-5	-6	-8	-8	-13	-15	-16
	-7	-9	-7	-8	-9	-11	-14	-20		-2	-5	-4	-7	-8	-11	-13	-19

Performance Data ISO 5801: The AMCA Certified Ratings Seal applies to air performance only

Performance shown is for installations type C – Ducted inlet, Ducted outlet. Performance ratings do not include the effects of appurtenances.

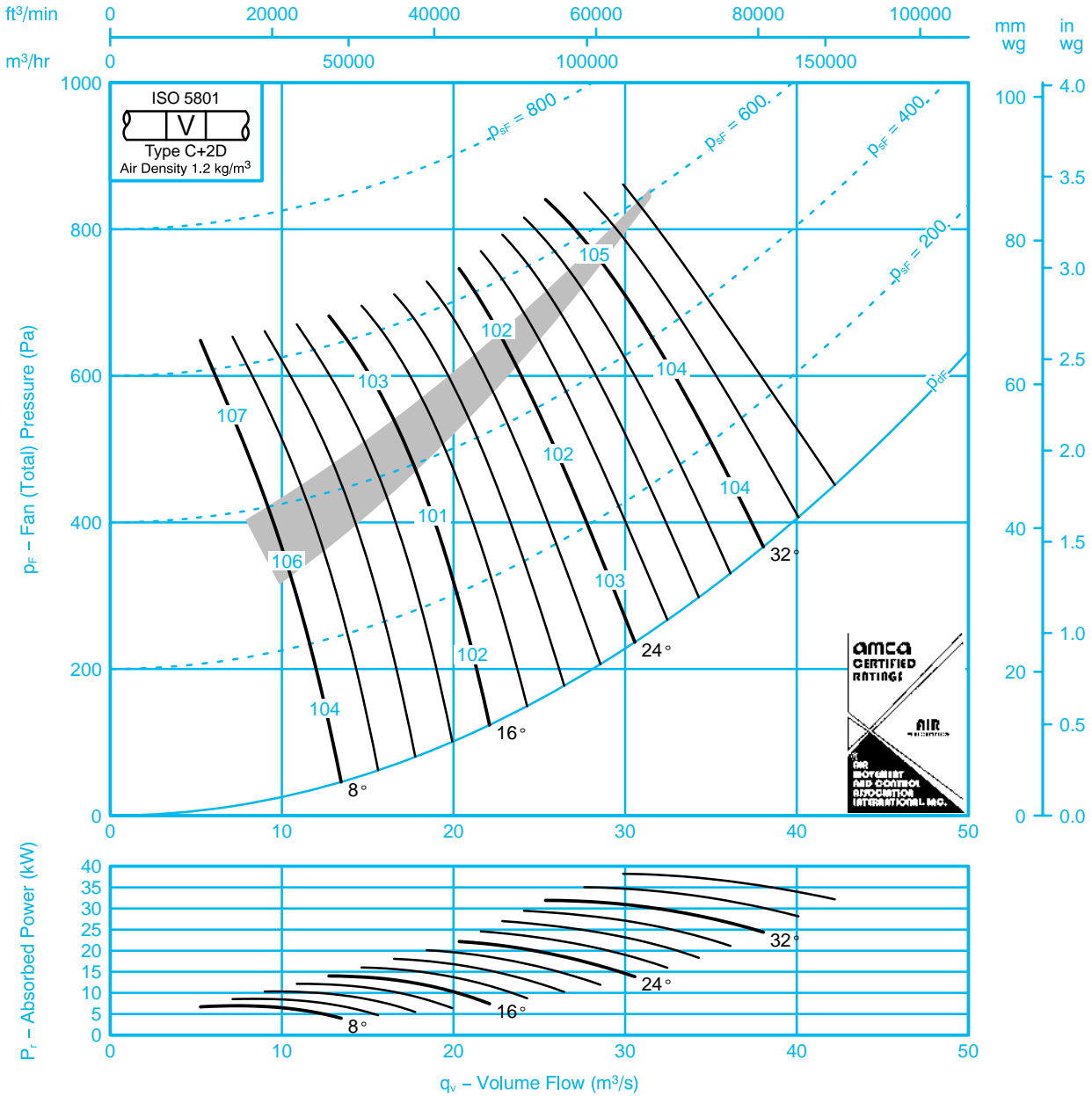

Sound Data BS848 Part 2 1985:

Single figures on performance curves are overall inlet sound power levels, derived from measurements taken in Woods laboratory specifically under ducted conditions. For sound power levels in eight octave bands, apply the following corrections to the overall level. Use upper corrections when operating point is above shaded area, or lower corrections when operating point is below shaded area.

Inlet Levels									Outlet Levels								
Pitch Angle	Octave Band Centre Frequency (Hz)								Pitch Angle	Octave Band Centre Frequency (Hz)							
	63	125	250	500	1k	2k	4k	8k		63	125	250	500	1k	2k	4k	8k
8	-17	-11	-9	-4	-6	-13	-18	-29	8	-15	-9	-7	-3	-5	-10	-16	-27
	-19	-14	-12	-6	-5	-7	-9	-22		-16	-13	-10	-6	-4	-5	-7	-20
16	-16	-15	-9	-3	-7	-14	-21	-27	16	-12	-13	-7	-3	-6	-13	-19	-26
	-10	-11	-7	-9	-8	-8	-9	-20		-7	-9	-4	-9	-8	-6	-6	-17
24 - 36	-5	-8	-8	-9	-9	-13	-16	-17	24 - 36	-2	-5	-6	-8	-8	-13	-15	-16
	-7	-9	-7	-8	-9	-11	-14	-20		-2	-5	-4	-7	-8	-11	-13	-19

Performance Data ISO 5801: The AMCA Certified Ratings Seal applies to air performance only

Performance shown is for installations type C – Ducted inlet, Ducted outlet. Performance ratings do not include the effects of appurtenances.

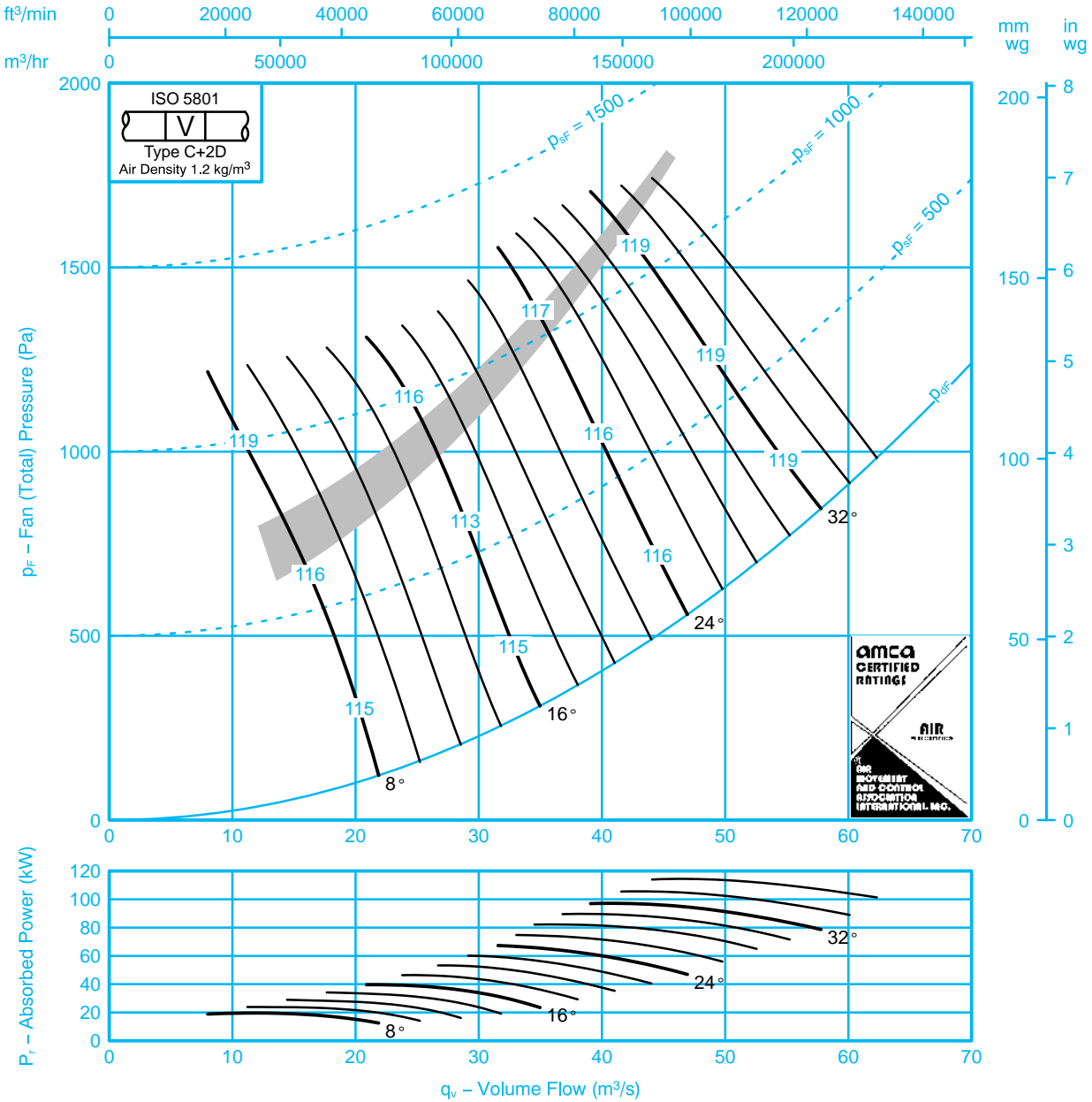

If it is intended to run this fan in reverse for other than emergency operation, please refer to Woods Air Movement.

Sound Data BS848 Part 2 1985:

Single figures on performance curves are overall inlet sound power levels, derived from measurements taken in Woods laboratory specifically under ducted conditions. For sound power levels in eight octave bands, apply the following corrections to the overall level. Use upper corrections when operating point is above shaded area, or lower corrections when operating point is below shaded area.

Inlet Levels									Outlet Levels								
Pitch Angle	Octave Band Centre Frequency (Hz)								Pitch Angle	Octave Band Centre Frequency (Hz)							
	63	125	250	500	1k	2k	4k	8k		63	125	250	500	1k	2k	4k	8k
8	-14	-16	-10	-7	-4	-8	-12	-20	8	-11	-14	-8	-6	-3	-7	-12	-18
	-10	-15	-10	-10	-5	-7	-8	-15		-7	-11	-8	-9	-5	-6	-7	-13
16	-11	-14	-10	-5	-5	-9	-14	-21	16	-8	-13	-8	-5	-4	-8	-13	-20
	-6	-10	-7	-10	-9	-10	-9	-15		-3	-7	-4	-8	-9	-8	-8	-14
24-36	-6	-9	-6	-9	-10	-13	-15	-17	24-36	-3	-6	-4	-8	-9	-12	-14	-16
	-5	-8	-6	-10	-11	-14	-15	-18		-2	-7	-3	-9	-10	-13	-14	-16

Performance Data ISO 5801: The AMCA Certified Ratings Seal applies to air performance only

Performance shown is for installations type C – Ducted inlet, Ducted outlet. Performance ratings do not include the effects of appurtenances.

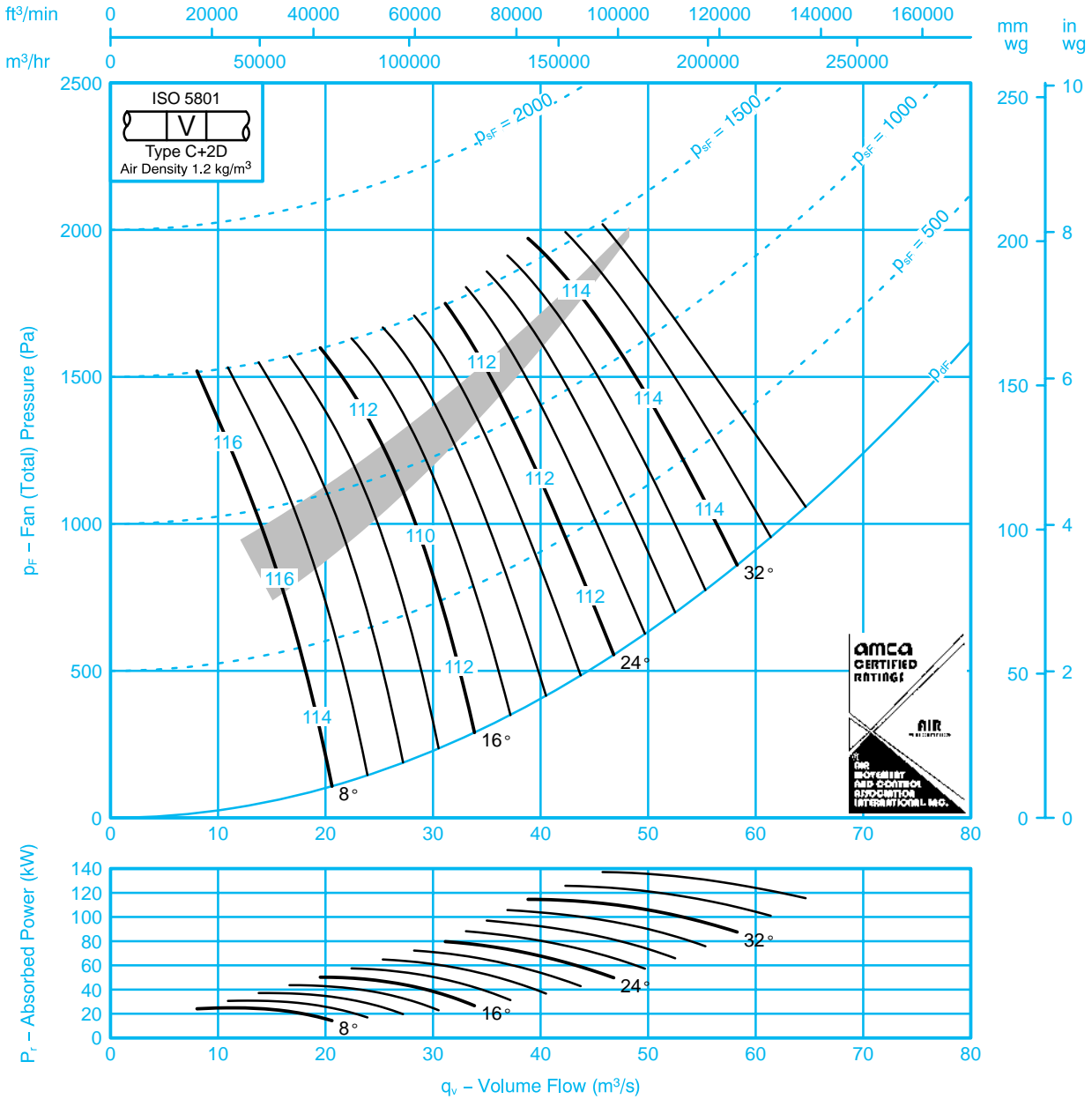

If it is intended to run this fan in reverse for other than emergency operation, please refer to Woods Air Movement.

Sound Data BS848 Part 2 1985:

Single figures on performance curves are overall inlet sound power levels, derived from measurements taken in Woods laboratory specifically under ducted conditions. For sound power levels in eight octave bands, apply the following corrections to the overall level. Use upper corrections when operating point is above shaded area, or lower corrections when operating point is below shaded area.

Inlet Levels									Outlet Levels								
Pitch Angle	Octave Band Centre Frequency (Hz)								Pitch Angle	Octave Band Centre Frequency (Hz)							
	63	125	250	500	1k	2k	4k	8k		63	125	250	500	1k	2k	4k	8k
8	-20	-16	-8	-9	-3	-8	-14	-22	8	-18	-14	-6	-8	-3	-5	-13	-21
	-21	-18	-12	-10	-5	-6	-7	-14		-19	-17	-10	-9	-3	-4	-5	-12
16	-18	-16	-12	-5	-4	-9	-16	-25	16	-15	-14	-11	-4	-3	-8	-14	-23
	-12	-11	-6	-11	-8	-8	-7	-14		-8	-9	-3	-10	-8	-7	-4	-11
24-36	-7	-6	-7	-10	-9	-11	-15	-17	24-36	-4	-3	-5	-9	-8	-11	-14	-17
	-8	-8	-6	-10	-9	-10	-12	-17		-5	-4	-3	-9	-8	-10	-11	-16

Performance Data ISO 5801: The AMCA Certified Ratings Seal applies to air performance only

Performance shown is for installations type C – Ducted inlet, Ducted outlet. Performance ratings do not include the effects of appurtenances.

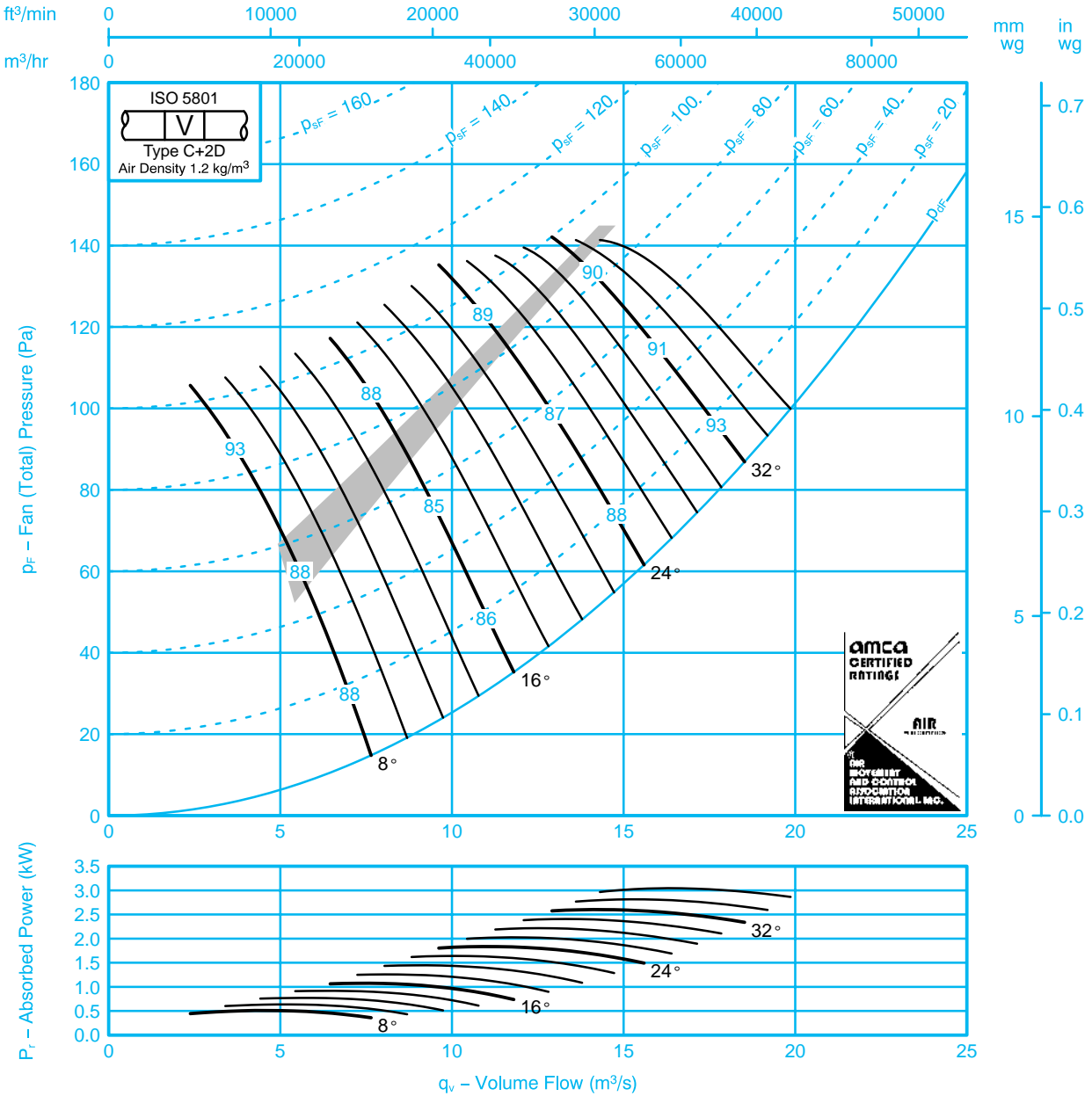

Sound Data BS848 Part 2 1985:

Single figures on performance curves are overall inlet sound power levels, derived from measurements taken in Woods laboratory specifically under ducted conditions. For sound power levels in eight octave bands, apply the following corrections to the overall level. Use upper corrections when operating point is above shaded area, or lower corrections when operating point is below shaded area.

Inlet Levels									Outlet Levels								
Pitch Angle	Octave Band Centre Frequency (Hz)								Pitch Angle	Octave Band Centre Frequency (Hz)							
	63	125	250	500	1k	2k	4k	8k		63	125	250	500	1k	2k	4k	8k
8	-13	-11	-3	-6	-11	-13	-26	-32	8	-11	-9	-3	-5	-10	-11	-25	-30
	-10	-12	-8	-5	-7	-8	-23	-30		-8	-10	-7	-5	-7	-7	-22	-29
16	-10	-10	-3	-7	-13	-17	-22	-26	16	-9	-9	-2	-7	-12	-17	-20	-25
	-5	-8	-8	-11	-9	-8	-20	-24		-3	-6	-8	-11	-8	-8	-19	-23
24-36	-5	-8	-7	-8	-13	-15	-17	-19	24-36	-3	-7	-6	-7	-12	-14	-15	-17
	-5	-7	-7	-10	-13	-14	-16	-18		-3	-6	-5	-8	-13	-13	-14	-16

Performance Data ISO 5801: The AMCA Certified Ratings Seal applies to air performance only

Performance shown is for installations type C – Ducted inlet, Ducted outlet. Performance ratings do not include the effects of appurtenances.

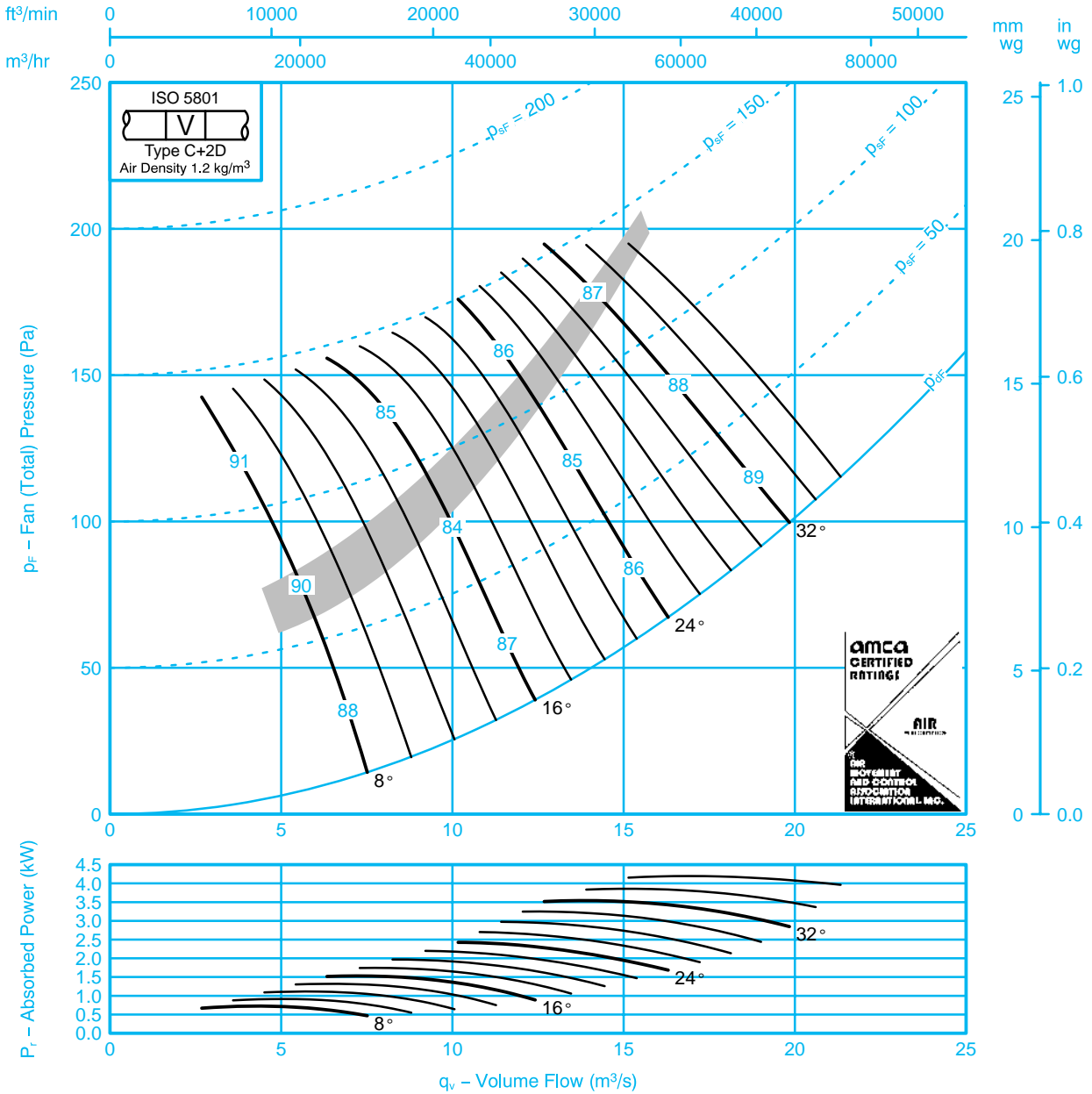

Sound Data BS848 Part 2 1985:

Single figures on performance curves are overall inlet sound power levels, derived from measurements taken in Woods laboratory specifically under ducted conditions. For sound power levels in eight octave bands, apply the following corrections to the overall level. Use upper corrections when operating point is above shaded area, or lower corrections when operating point is below shaded area.

Inlet Levels									Outlet Levels								
Pitch Angle	Octave Band Centre Frequency (Hz)								Pitch Angle	Octave Band Centre Frequency (Hz)							
	63	125	250	500	1k	2k	4k	8k		63	125	250	500	1k	2k	4k	8k
8	-14	-11	-4	-5	-10	-14	-25	-31	8	-11	-9	-3	-3	-9	-12	-25	-30
	-13	-13	-8	-6	-5	-7	-22	-28		-10	-11	-8	-5	-4	-5	-21	-27
16	-8	-10	-6	-7	-9	-10	-17	-20	16	-5	-8	-5	-7	-7	-10	-15	-19
	-9	-11	-9	-8	-5	-7	-19	-24		-5	-9	-8	-8	-4	-6	-19	-22
24 - 36	-5	-9	-7	-8	-11	-14	-14	-15	24 - 36	-1	-6	-5	-7	-11	-13	-13	-14
	-5	-8	-7	-8	-10	-14	-17	-19		-1	-5	-4	-7	-9	-13	-15	-17

Performance Data ISO 5801: The AMCA Certified Ratings Seal applies to air performance only

Performance shown is for installations type C – Ducted inlet, Ducted outlet. Performance ratings do not include the effects of appurtenances.

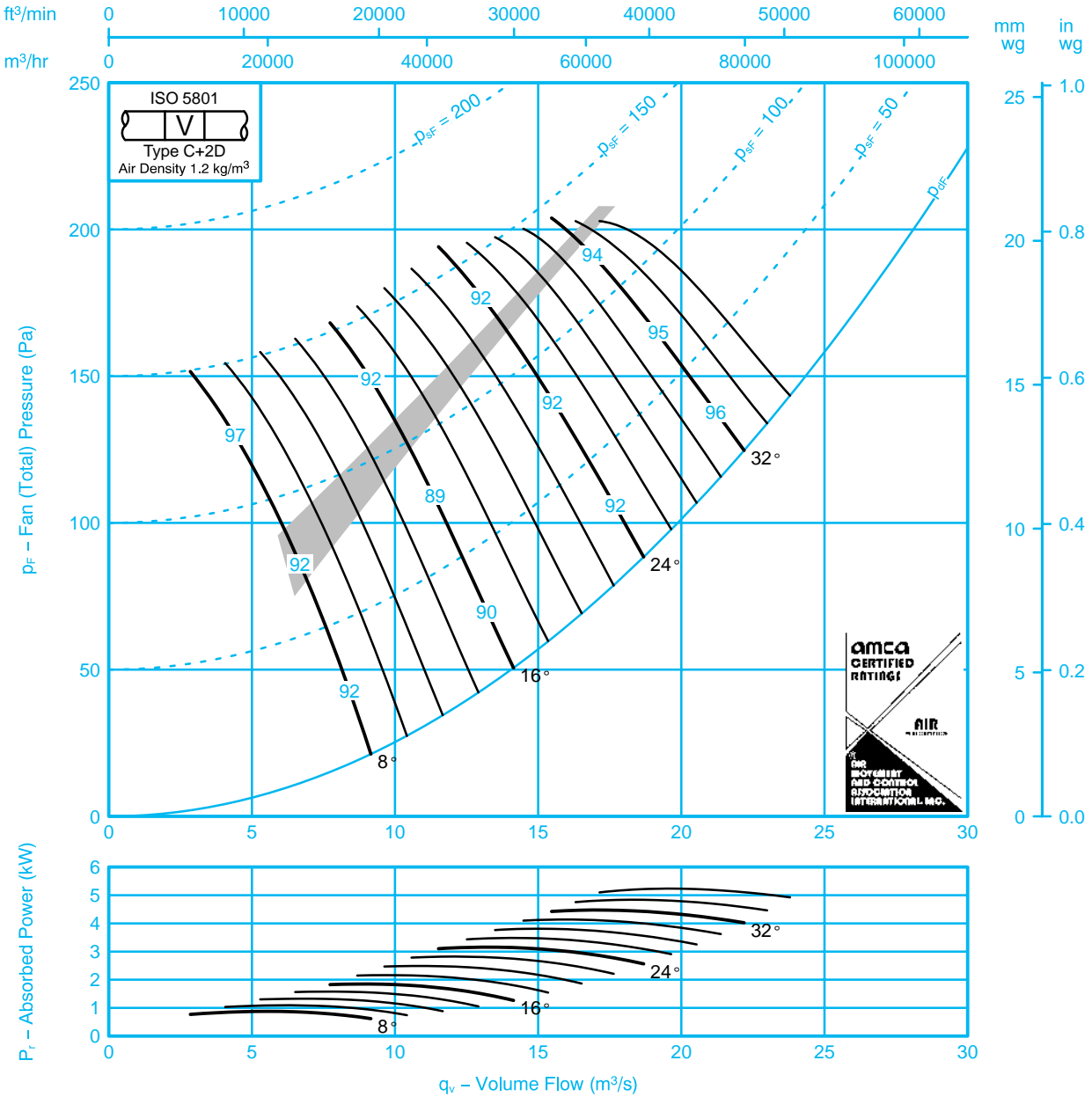

Sound Data BS848 Part 2 1985:

Single figures on performance curves are overall inlet sound power levels, derived from measurements taken in Woods laboratory specifically under ducted conditions. For sound power levels in eight octave bands, apply the following corrections to the overall level. Use upper corrections when operating point is above shaded area, or lower corrections when operating point is below shaded area.

Inlet Levels									Outlet Levels								
Pitch Angle	Octave Band Centre Frequency (Hz)								Pitch Angle	Octave Band Centre Frequency (Hz)							
	63	125	250	500	1k	2k	4k	8k		63	125	250	500	1k	2k	4k	8k
8	-17	-12	-5	-4	-9	-11	-22	-29	8	-14	-10	-4	-4	-9	-10	-22	-28
	-15	-10	-9	-5	-7	-7	-19	-28		-12	-8	-8	-4	-6	-5	-18	-27
16	-13	-10	-4	-4	-11	-16	-21	-24	16	-11	-9	-4	-4	-11	-16	-19	-23
	-8	-6	-8	-10	-9	-8	-17	-23		-5	-4	-7	-10	-9	-7	-16	-22
24-36	-8	-5	-7	-8	-12	-15	-16	-18	24-36	-6	-4	-6	-6	-11	-13	-15	-16
	-7	-5	-7	-8	-12	-14	-16	-17		-4	-4	-5	-7	-12	-13	-14	-16



Fan Code: 140JM/40/10/9/...

1400 mm 575 rev/min 9 Blades 50 Hz

Performance Data ISO 5801: The AMCA Certified Ratings Seal applies to air performance only

Performance shown is for installations type C – Ducted inlet, Ducted outlet. Performance ratings do not include the effects of appurtenances.

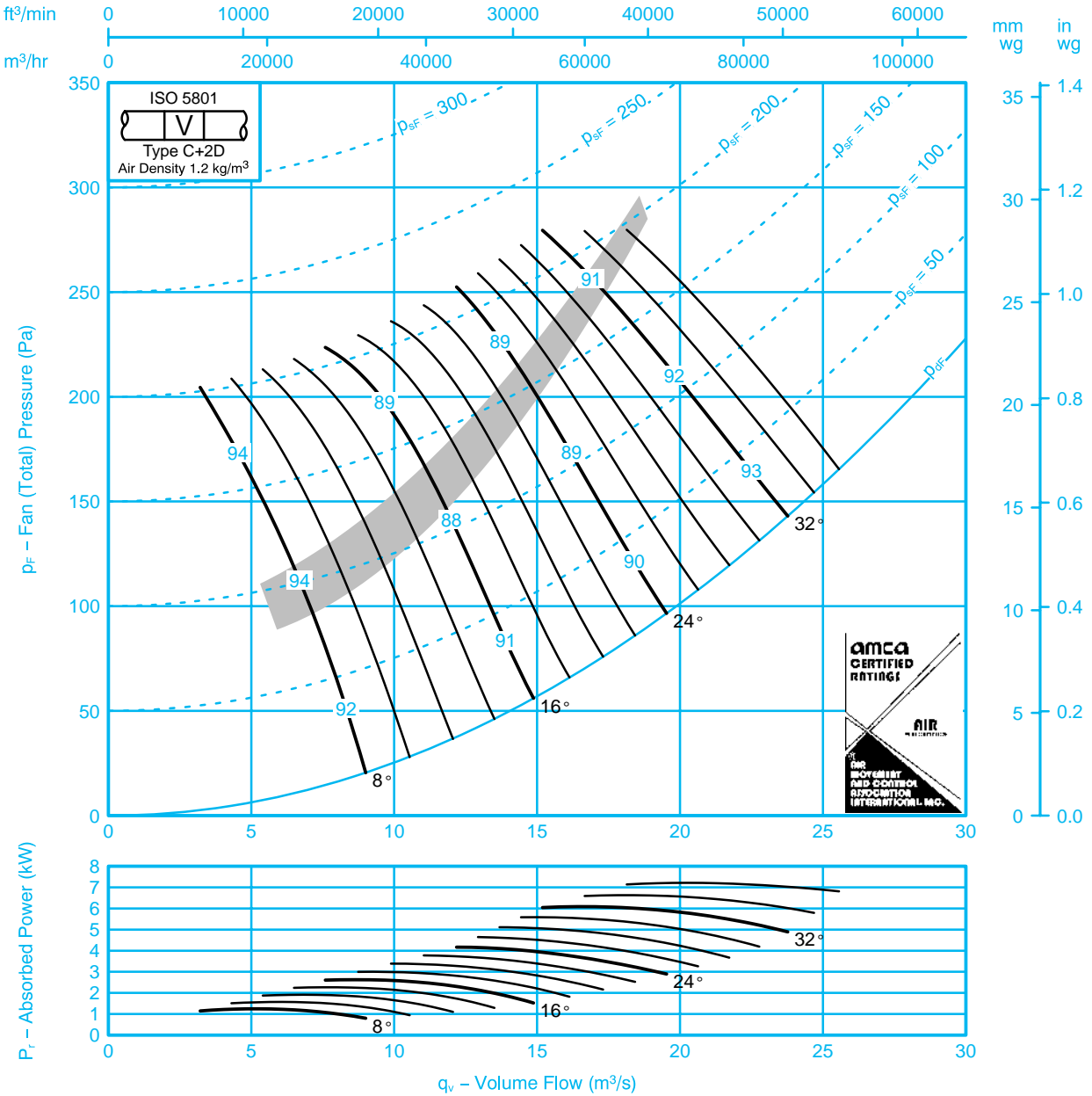

Sound Data BS848 Part 2 1985:

Single figures on performance curves are overall inlet sound power levels, derived from measurements taken in Woods laboratory specifically under ducted conditions. For sound power levels in eight octave bands, apply the following corrections to the overall level. Use upper corrections when operating point is above shaded area, or lower corrections when operating point is below shaded area.

Inlet Levels								Outlet Levels									
Pitch Angle	Octave Band Centre Frequency (Hz)							Pitch Angle	Octave Band Centre Frequency (Hz)								
	63	125	250	500	1k	2k	4k		8k	63	125	250	500	1k	2k	4k	8k
8	-15	-12	-6	-4	-9	-12	-23	-28	8	-12	-10	-5	-2	-8	-11	-24	-28
	-14	-15	-9	-6	-6	-5	-18	-26		-11	-12	-9	-5	-5	-3	-18	-25
16	-8	-12	-6	-6	-9	-9	-16	-19	16	-5	-10	-6	-6	-7	-8	-14	-18
	-9	-13	-9	-8	-7	-5	-17	-22		-6	-10	-7	-8	-5	-5	-17	-20
24 - 36	-6	-10	-7	-7	-10	-14	-14	-14	24 - 36	-1	-7	-5	-7	-9	-13	-13	-13
	-6	-9	-6	-8	-10	-13	-16	-17		-1	-6	-4	-7	-8	-12	-14	-16

Performance Data ISO 5801: The AMCA Certified Ratings Seal applies to air performance only

Performance shown is for installations type C – Ducted inlet, Ducted outlet. Performance ratings do not include the effects of appurtenances.

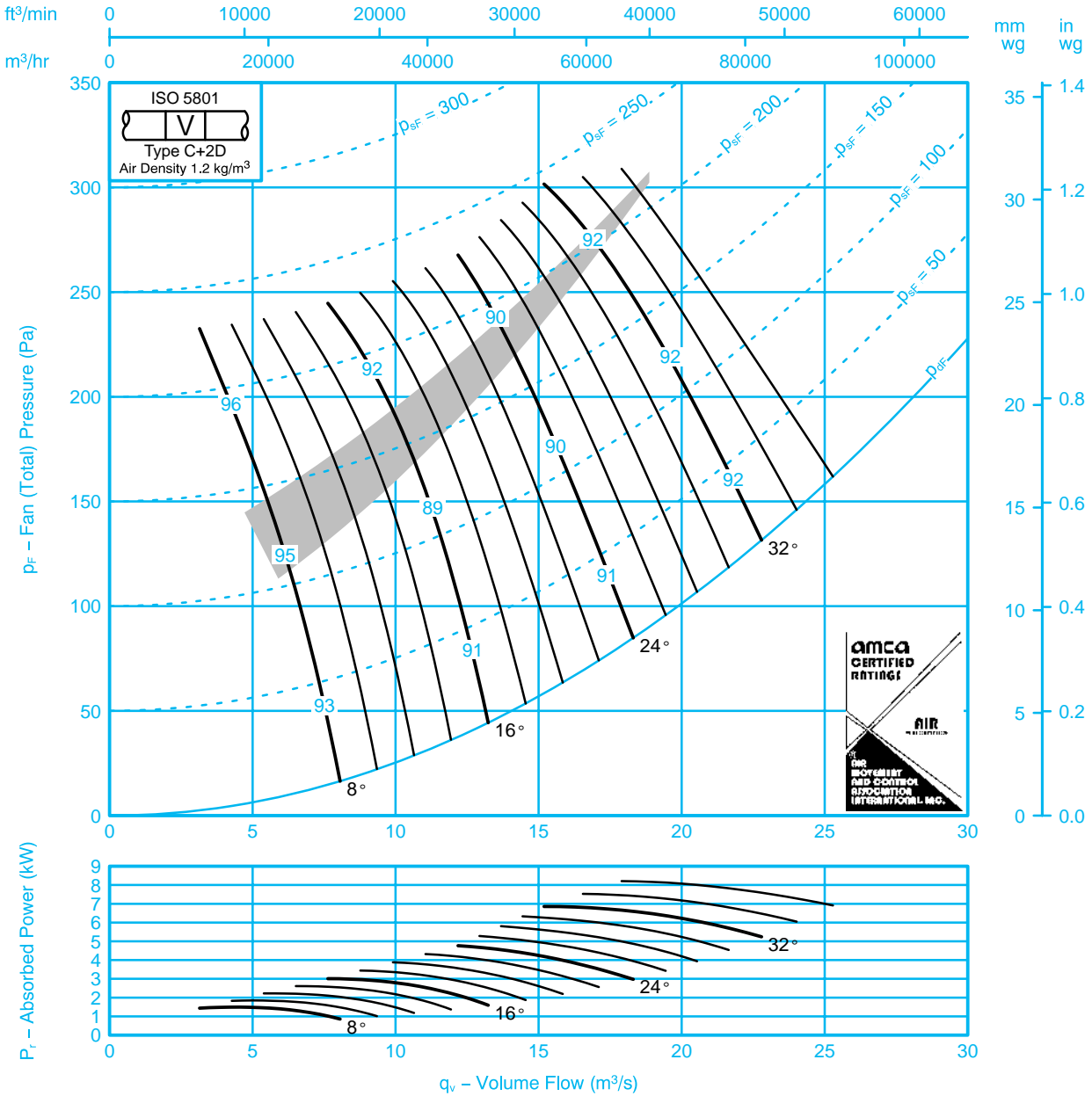

Sound Data BS848 Part 2 1985:

Single figures on performance curves are overall inlet sound power levels, derived from measurements taken in Woods laboratory specifically under ducted conditions. For sound power levels in eight octave bands, apply the following corrections to the overall level. Use upper corrections when operating point is above shaded area, or lower corrections when operating point is below shaded area.

Inlet Levels									Outlet Levels								
Pitch Angle	Octave Band Centre Frequency (Hz)								Pitch Angle	Octave Band Centre Frequency (Hz)							
	63	125	250	500	1k	2k	4k	8k		63	125	250	500	1k	2k	4k	8k
8	-13	-8	-5	-5	-11	-16	-27	-32	8	-11	-5	-5	-4	-10	-14	-25	-30
	-15	-12	-8	-4	-7	-8	-20	-26		-13	-10	-8	-4	-6	-6	-18	-24
16	-16	-10	-3	-5	-12	-19	-26	-29	16	-12	-7	-2	-5	-11	-19	-24	-28
	-12	-6	-9	-7	-8	-8	-18	-22		-8	-3	-9	-8	-7	-6	-15	-19
24-36	-7	-6	-8	-7	-11	-15	-16	-16	24-36	-4	-2	-7	-6	-10	-14	-14	-15
	-8	-5	-8	-8	-10	-12	-18	-20		-4	0	-6	-7	-9	-12	-17	-19



Fan Code: 160JM/40/8/6/...

1600 mm 720 rev/min 6 Blades 50 Hz

Performance Data ISO 5801: The AMCA Certified Ratings Seal applies to air performance only

Performance shown is for installations type C – Ducted inlet, Ducted outlet. Performance ratings do not include the effects of appurtenances.

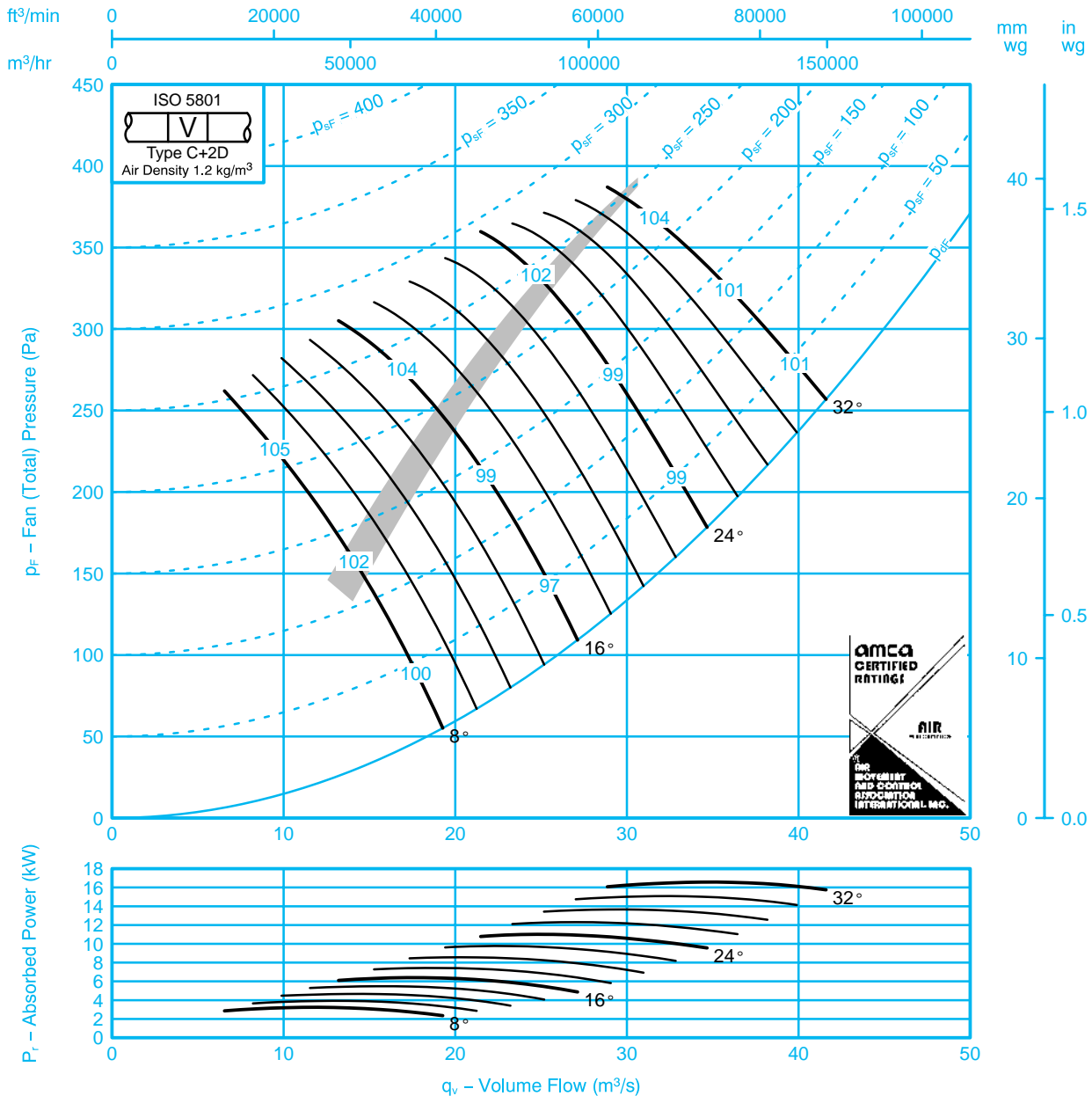

If it is intended to run this fan in reverse for other than emergency operation, please refer to Woods Air Movement.

Sound Data BS848 Part 2 1985:

Single figures on performance curves are overall inlet sound power levels, derived from measurements taken in Woods laboratory specifically under ducted conditions. For sound power levels in eight octave bands, apply the following corrections to the overall level. Use upper corrections when operating point is above shaded area, or lower corrections when operating point is below shaded area.

Inlet Levels									Outlet Levels								
Pitch Angle	Octave Band Centre Frequency (Hz)								Pitch Angle	Octave Band Centre Frequency (Hz)							
	63	125	250	500	1k	2k	4k	8k		63	125	250	500	1k	2k	4k	8k
8	-19	-12	-5	-4	-9	-14	-18	-26	8	-16	-9	-4	-4	-8	-13	-17	-24
	-16	-13	-11	-6	-5	-8	-11	-23		-13	-11	-10	-5	-4	-6	-10	-22
16	-15	-13	-10	-4	-6	-10	-13	-17	16	-13	-12	-9	-4	-6	-10	-12	-16
	-10	-9	-9	-7	-8	-8	-10	-15		-7	-7	-9	-7	-7	-8	-9	-14
24 - 32	-13	-7	-6	-6	-10	-15	-17	-19	24 - 32	-10	-6	-6	-5	-9	-13	-15	-18
	-9	-7	-8	-7	-8	-11	-12	-13		-6	-6	-7	-6	-8	-10	-10	-12