

Performance Data ISO 5801: The AMCA Certified Ratings Seal applies to air performance only

Performance shown is for installations type D—Ducted inlet, Ducted outlet. Performance ratings do not include the effects of appurtenances.

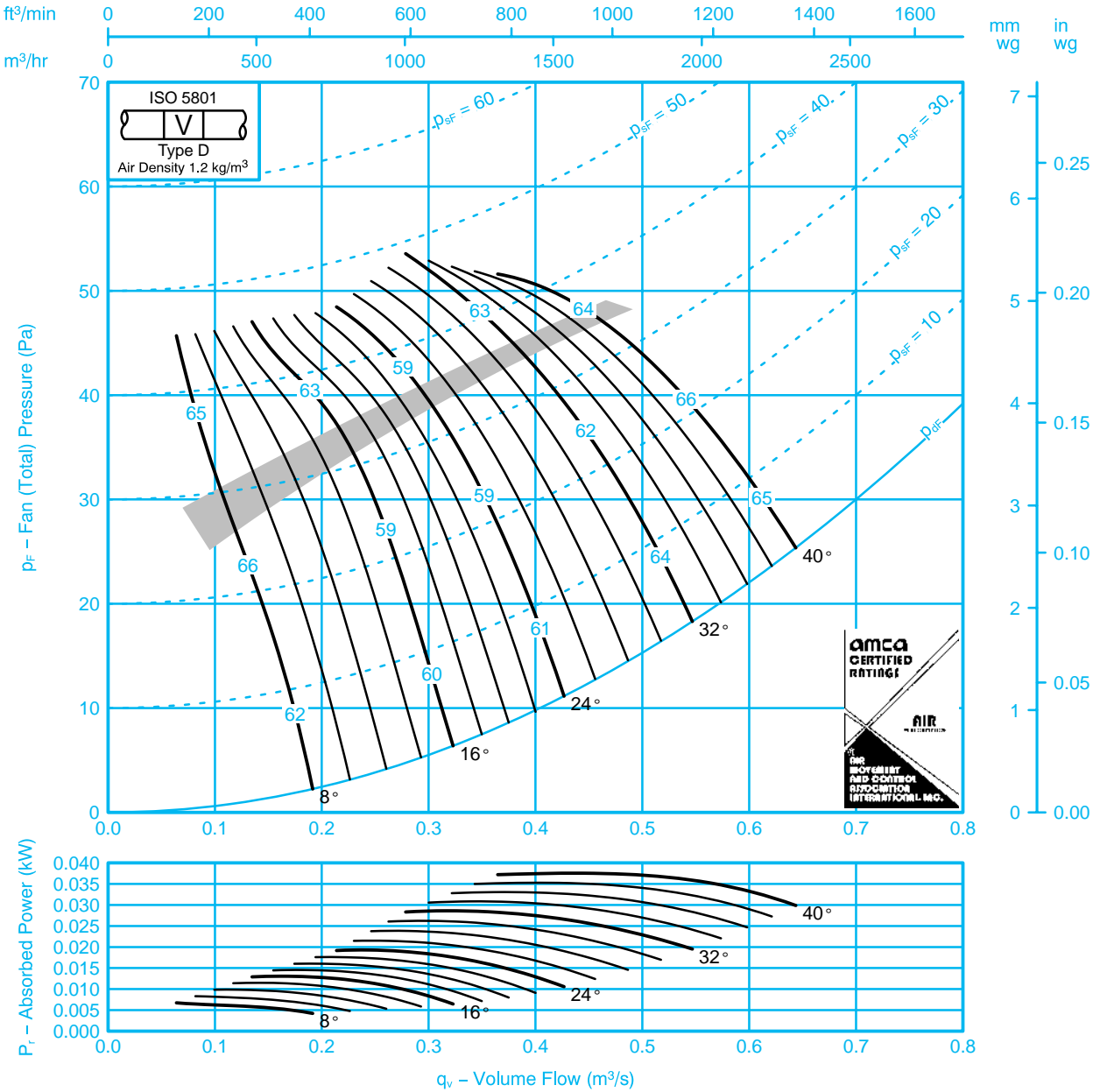

Sound Data BS848 Part 2 1985:

Single figures on performance curves are overall inlet sound power levels, derived from measurements taken in Woods laboratory specifically under ducted conditions. For sound power levels in eight octave bands, apply the following corrections to the overall level. Use upper corrections when operating point is above shaded area, or lower corrections when operating point is below shaded area.

Inlet Levels									Outlet Levels								
Pitch Angle	Octave Band Centre Frequency (Hz)								Pitch Angle	Octave Band Centre Frequency (Hz)							
	63	125	250	500	1k	2k	4k	8k		63	125	250	500	1k	2k	4k	8k
8	-6	-6	-4	-10	-18	-25	-32	-41	8	-3	-5	-4	-10	-18	-24	-32	-40
	-10	-9	-3	-7	-14	-19	-28	-35		-8	-8	-3	-7	-14	-19	-27	-33
16	-6	-7	-4	-12	-14	-19	-25	-30	16	-3	-6	-4	-12	-13	-18	-25	-30
	-6	-7	-6	-8	-11	-15	-22	-26		-3	-7	-6	-8	-11	-14	-22	-26
24-40	-4	-6	-6	-11	-16	-21	-25	-32	24-40	-2	-6	-6	-11	-15	-19	-24	-30
	-4	-7	-6	-11	-14	-18	-25	-30		-1	-6	-6	-11	-14	-18	-24	-29



Fan Code: 35JM/16/4/5/...

355 mm 1420 rev/min 5 Blades 50 Hz

Performance Data ISO 5801: The AMCA Certified Ratings Seal applies to air performance only

Performance shown is for installations type D—Ducted inlet, Ducted outlet. Performance ratings do not include the effects of appurtenances.

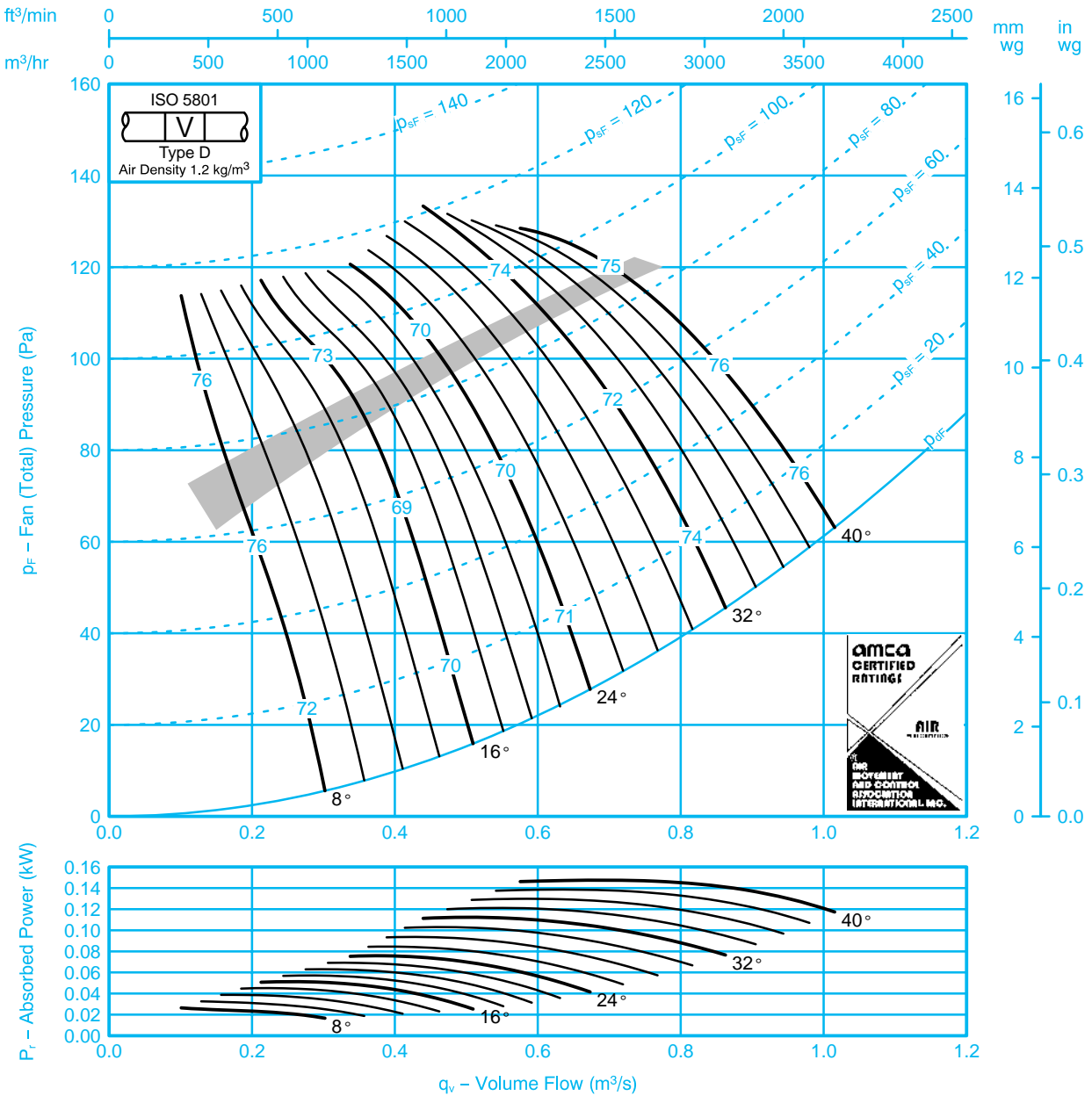

Sound Data BS848 Part 2 1985:

Single figures on performance curves are overall inlet sound power levels, derived from measurements taken in Woods laboratory specifically under ducted conditions. For sound power levels in eight octave bands, apply the following corrections to the overall level. Use upper corrections when operating point is above shaded area, or lower corrections when operating point is below shaded area.

Inlet Levels									Outlet Levels								
Pitch Angle	Octave Band Centre Frequency (Hz)								Pitch Angle	Octave Band Centre Frequency (Hz)							
	63	125	250	500	1k	2k	4k	8k		63	125	250	500	1k	2k	4k	8k
8	-9	-7	-5	-5	-13	-20	-27	-35	8	-6	-5	-4	-5	-13	-20	-27	-35
	-14	-10	-7	-3	-10	-16	-22	-31		-12	-8	-7	-3	-9	-16	-20	-29
16	-12	-6	-6	-5	-13	-15	-21	-27	16	-10	-3	-6	-5	-12	-14	-21	-27
	-10	-6	-7	-6	-9	-12	-17	-24		-9	-3	-6	-6	-9	-12	-17	-24
24-40	-5	-6	-7	-8	-14	-18	-23	-28	24-40	-3	-5	-7	-7	-13	-17	-21	-26
	-7	-5	-8	-7	-12	-16	-21	-27		-5	-2	-7	-7	-12	-16	-20	-26



Fan Code: 35JM/16/2/5/...

355 mm 2840 rev/min 5 Blades 50 Hz

Performance Data ISO 5801: The AMCA Certified Ratings Seal applies to air performance only

Performance shown is for installations type D—Ducted inlet, Ducted outlet. Performance ratings do not include the effects of appurtenances.

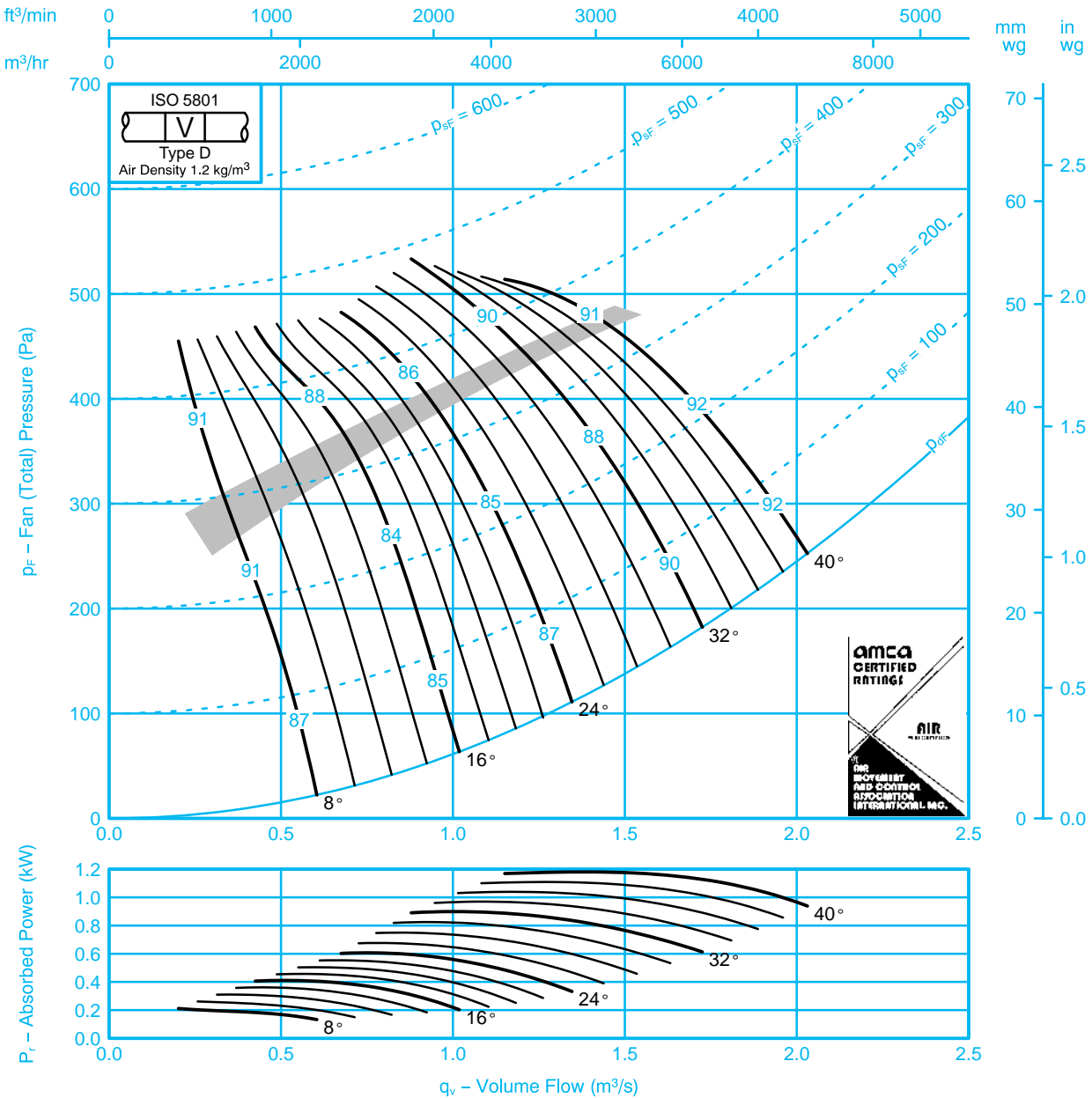

Sound Data BS848 Part 2 1985:

Single figures on performance curves are overall inlet sound power levels, derived from measurements taken in Woods laboratory specifically under ducted conditions. For sound power levels in eight octave bands, apply the following corrections to the overall level. Use upper corrections when operating point is above shaded area, or lower corrections when operating point is below shaded area.

Inlet Levels									Outlet Levels								
Pitch Angle	Octave Band Centre Frequency (Hz)								Pitch Angle	Octave Band Centre Frequency (Hz)							
	63	125	250	500	1k	2k	4k	8k		63	125	250	500	1k	2k	4k	8k
8	-13	-9	-7	-5	-6	-13	-21	-28	8	-10	-8	-5	-4	-5	-12	-21	-27
	-17	-14	-10	-7	-3	-10	-16	-22		-15	-14	-8	-7	-3	-9	-15	-20
16	-12	-12	-6	-7	-5	-13	-16	-22	16	-11	-12	-3	-6	-5	-12	-16	-21
	-11	-11	-7	-7	-7	-10	-13	-17		-10	-11	-4	-7	-6	-9	-13	-17
24-40	-8	-6	-7	-8	-9	-14	-19	-24	24 40	-6	-5	-6	-7	-8	-13	-17	-22
	-8	-8	-6	-8	-8	-13	-17	-22		-5	-7	-3	-8	-8	-13	-16	-21